

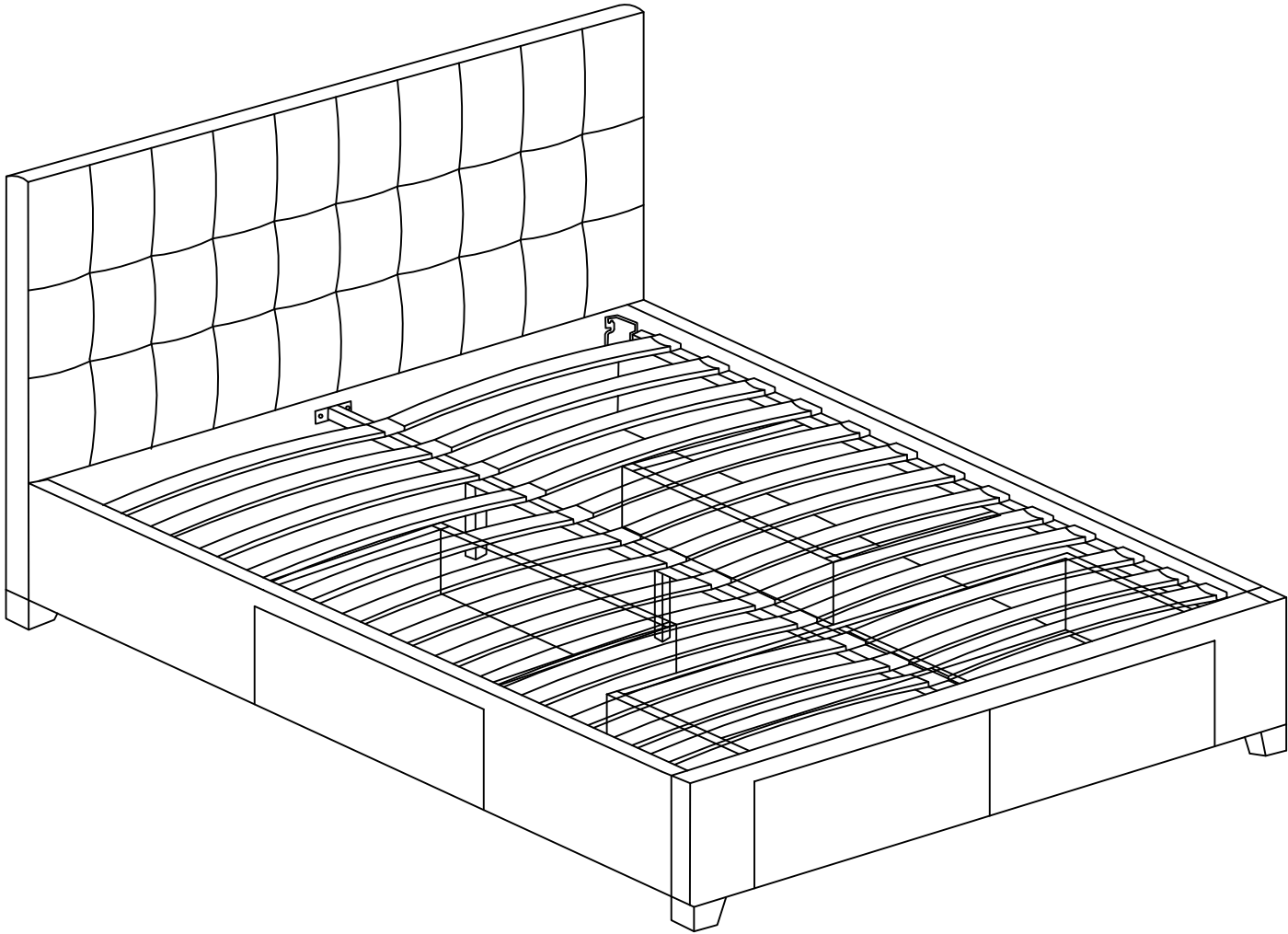

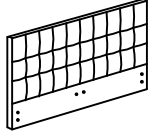







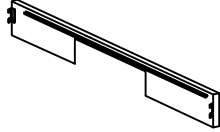

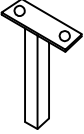



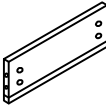
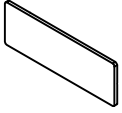
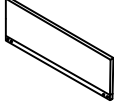
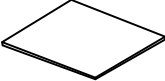

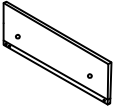

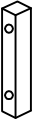
Assembly Instruction 89546-4

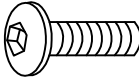
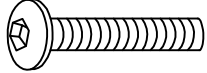
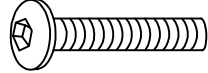

# PART LIST

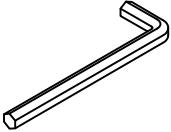
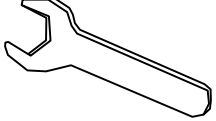
1.Headboard 1pc 	2.Footboard 1pc 	3.Side Rail*2pcs 
4.Metal Bar 1pc 	5.Support Leg *2pcs 	6.Slats*26pcs 
7.Single Plastic Cap*26pcs 	8.Double Plastic Cap*13pcs 	9.Leg*4pcs 
10. PANEL X8 	11.FRONT-PANEL X4 	12.PANEL X4 
13.BOTTOM X4 	14.BOTTOM SUPPORT X8 	15.PANEL X4 
16.WHEEL X16 	17. X4 	

# HARDWARE LIST

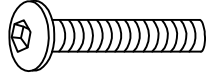
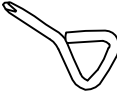
(A)Bolt M8*30mm*20pcs 	(B)Bolt M8*35mm*4pcs 	(C)Bolt M8*50mm*4pcs 
(D)Spring Washer*8pcs 	(E)Nut M8*4pcs 	(F)Flat Washer *20pcs 
(G)Allen Key M5*1pc 	(H)Spanner *1pc 	(I)TAPPING SCREW X64  M4*13mm
(J)TAPPING SCREW X64  M4*40mm	(K) *64pcs 	(L)Bolt M8*45mm*8pcs 
(M) * 1pc 		

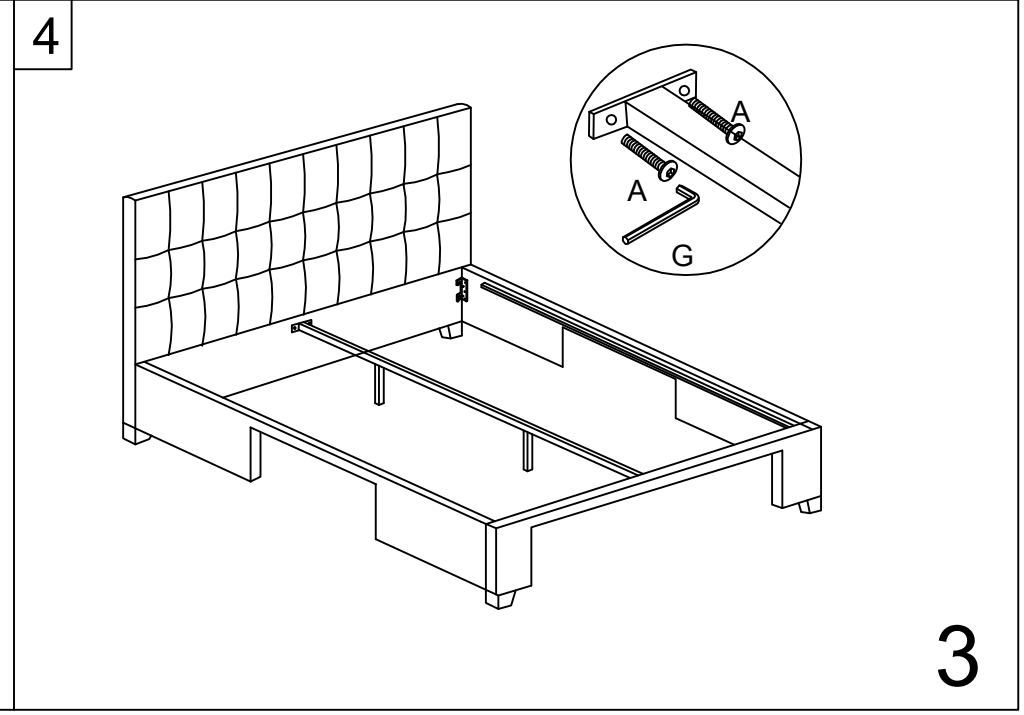
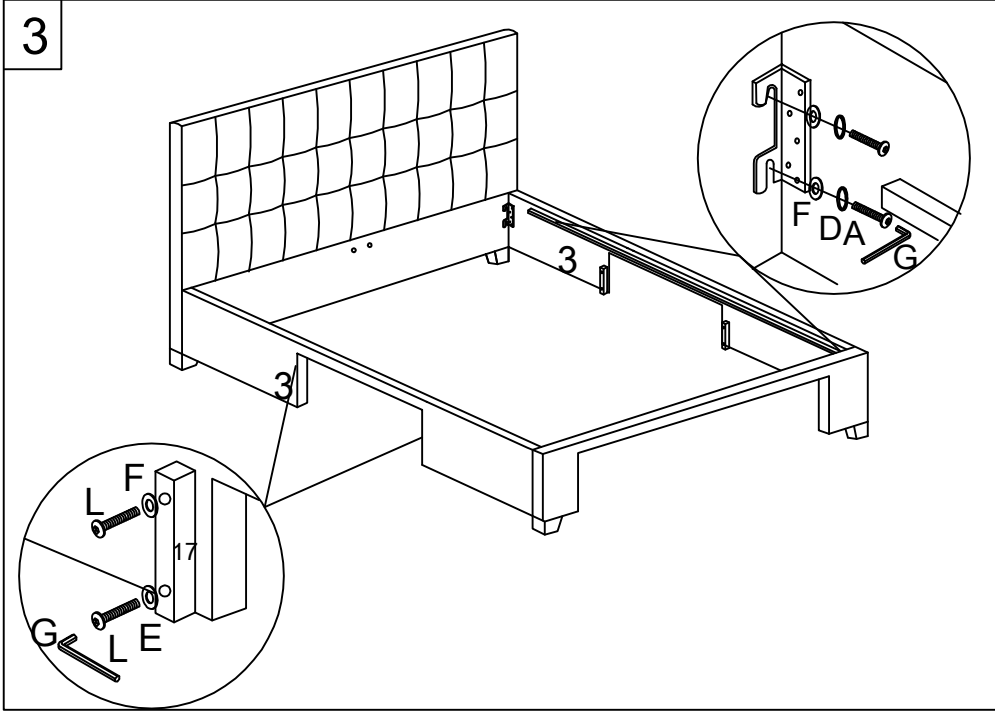
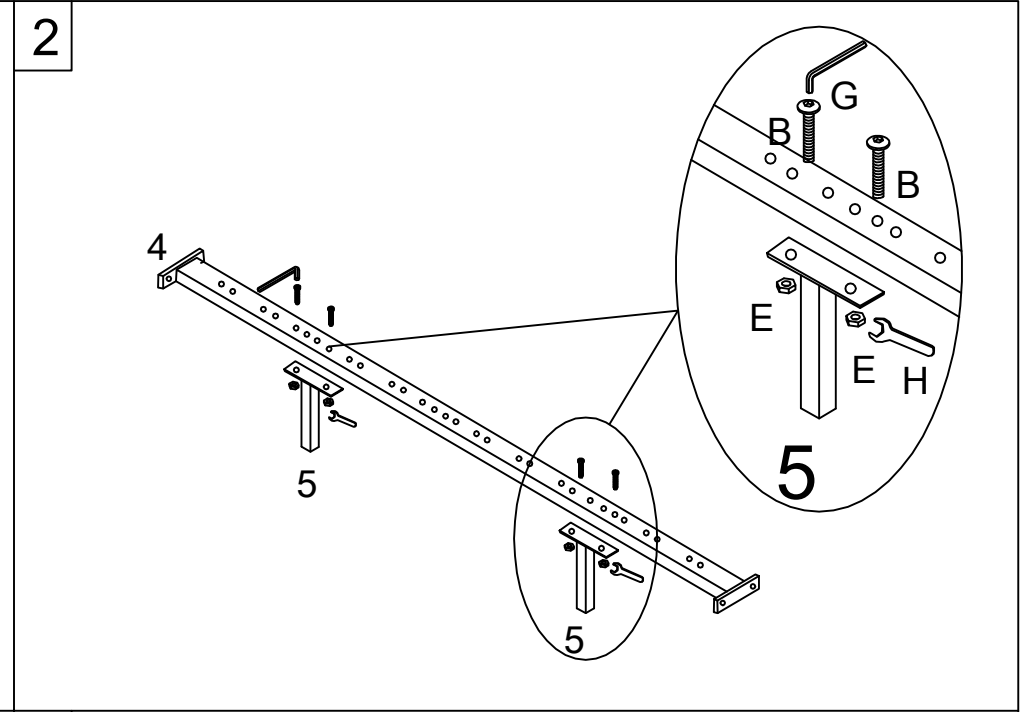
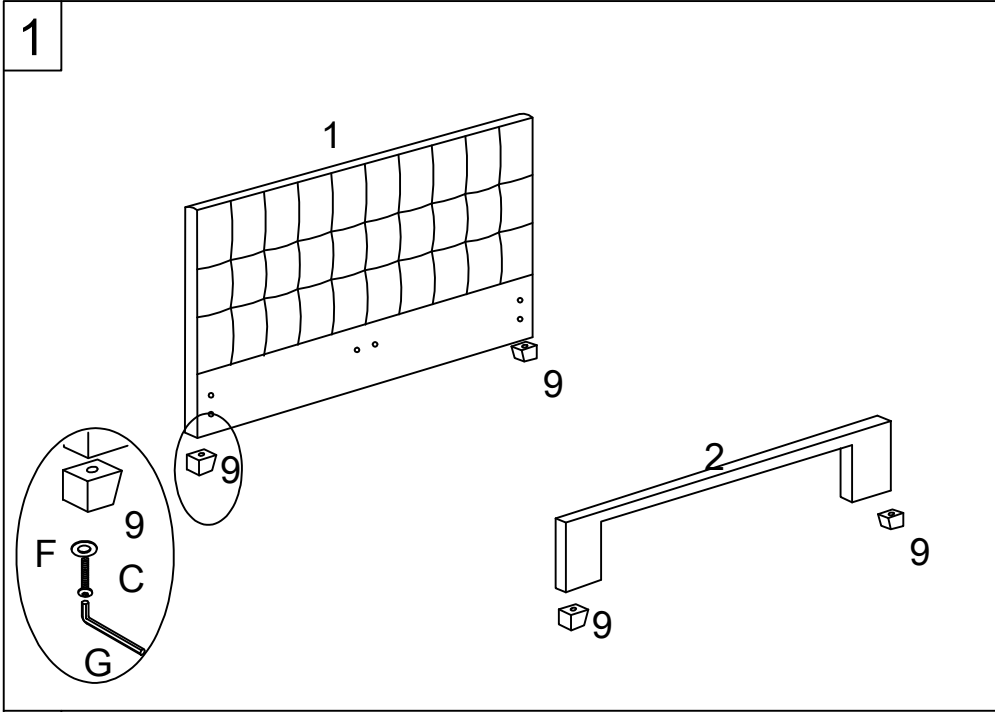

5

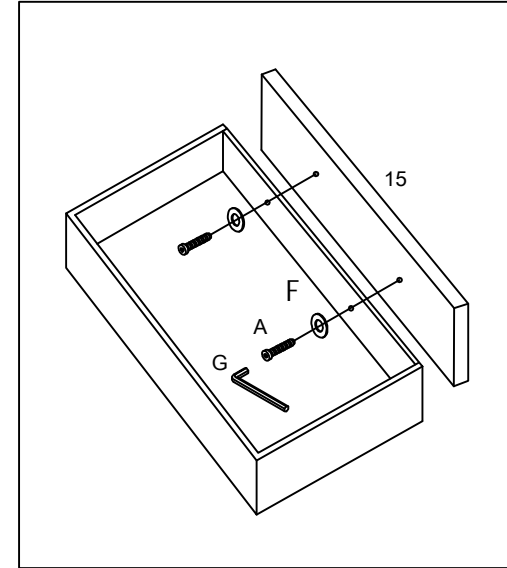
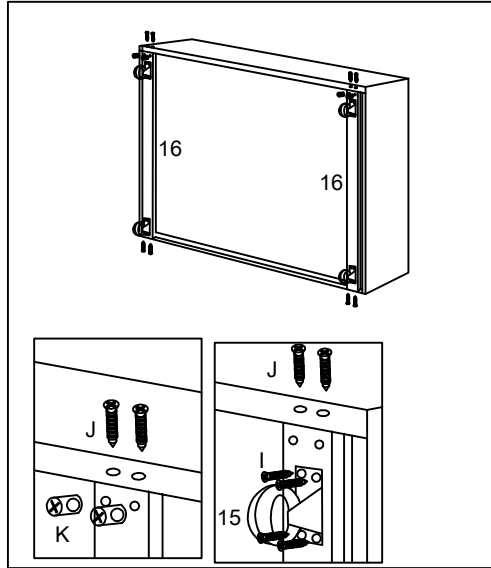
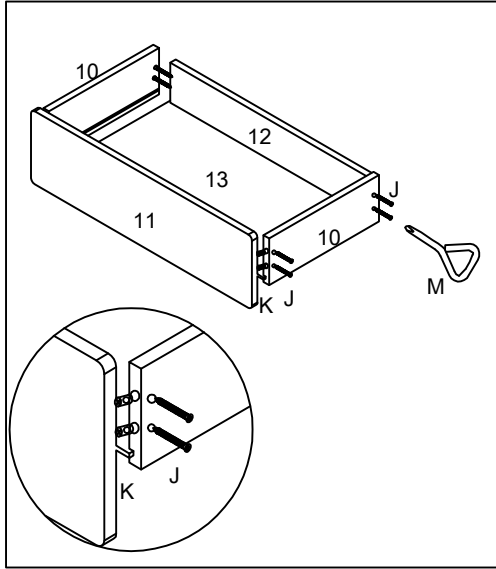

6

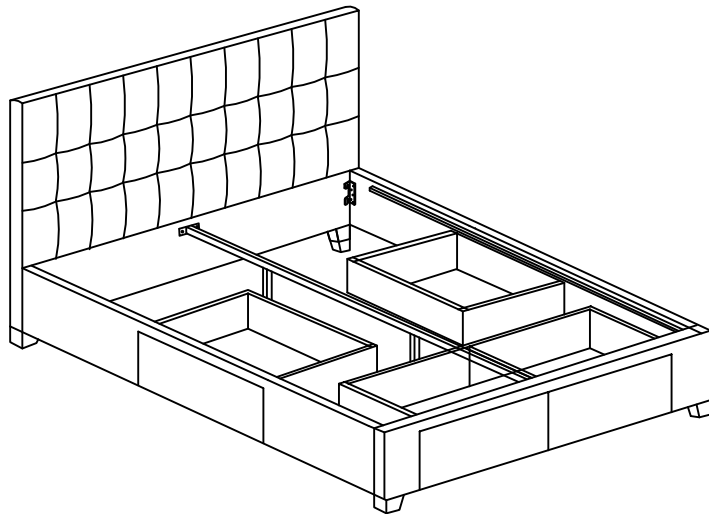

7

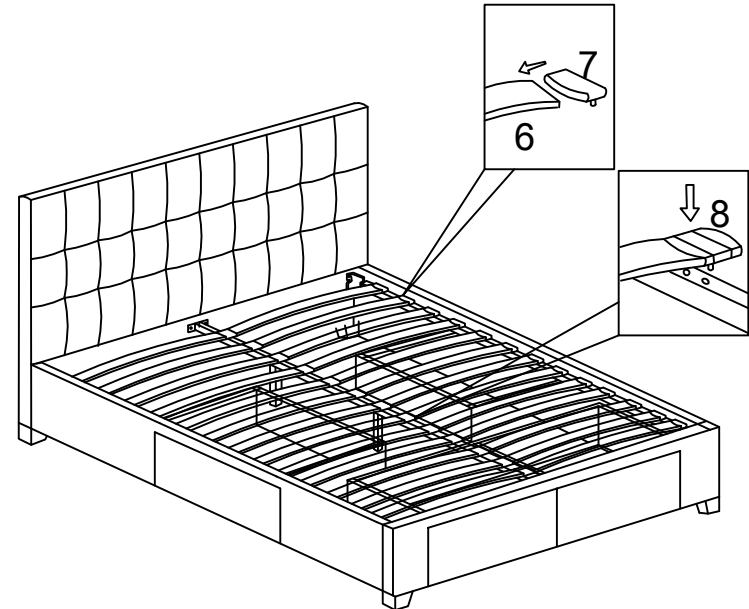

4