









ASSEMBLING INSTRUCTIONS

CAUTION :

THIS ITEM IS MADE OF LAMINATED PARTICLE BOARD AND MEDIUM DENSITY FIBRE BOARD TO BE ASSEMBLED ON A DRY, SOFT, SMOOTH AND CLEAN SURFACE . DO NOT USE DETERGENT OR CHEMICAL. AVOID DAMP AND DIRECT SUNLIGHT.

STEP 1	CHECK YOUR HARDWARE	H1859A
	SCREW #9 X 1 1/2"	20 PCS
	WOOD DOWEL M8 X 25	24 PCS
	SCREW #9 X 2"	24 PCS
	SCREW CAP	40 PCS
	SCREW M3.5 X 14	2 PCS
	METAL PLATE	2 PCS

TOOLS REQUIRED		
	SCREW DRIVER	
		HAMMER

STEP 2

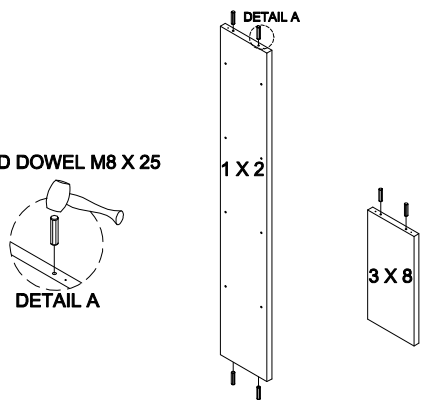

WOOD DOWEL M8 X 25

1 X 2

3 X 8

DETAIL A

STEP 3

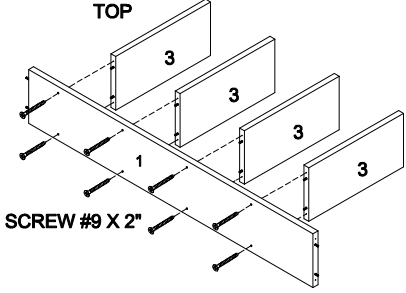

TOP

3

3

3

3

1

SCREW #9 X 2"

STEP 4

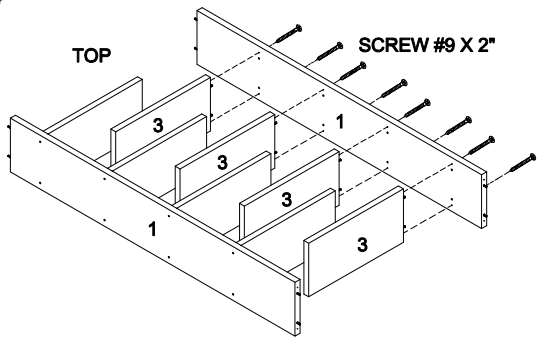

TOP

3

3

3

1

3

3

SCREW #9 X 2"

STEP 5

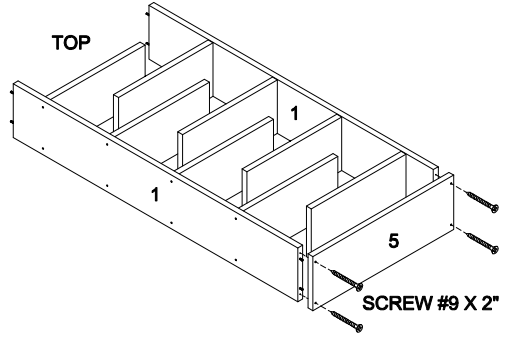

TOP

1

1

5

SCREW #9 X 2"

STEP 6

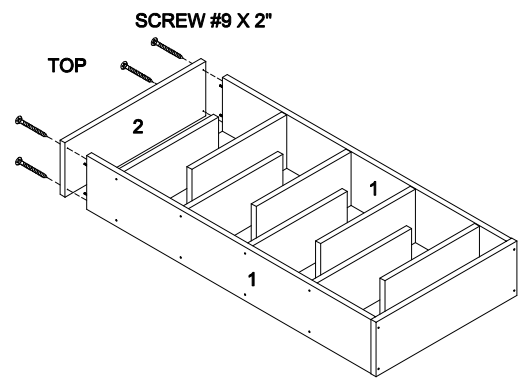

SCREW #9 X 2"

TOP

2

1

1

STEP 7

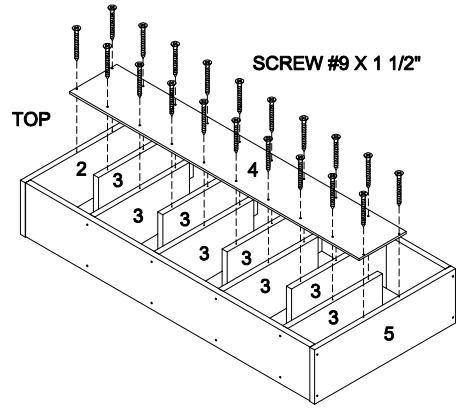

SCREW #9 X 1 1/2"

TOP

2

3

3

4

3

3

3

3

3

3

5

BACK VIEW

STEP 8

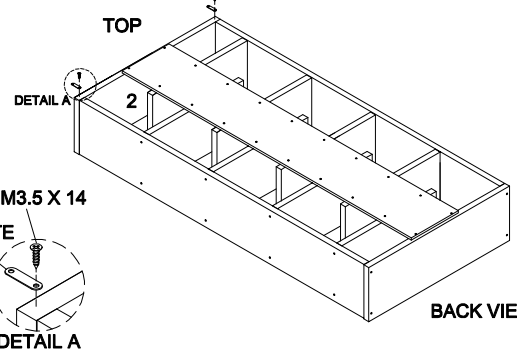

TOP

DETAIL A

2

1

SCREW M3.5 X 14

METAL PLATE

DETAIL A

BACK VIEW

STEP 9

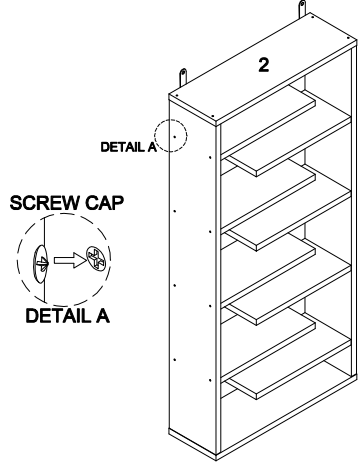

DETAIL A

2

SCREW CAP

DETAIL A

SCREW AND WALL PLUG ARE NOT PROVIDED. PLEASE USE APPROPRIATE FEATURES FOR YOUR WALL.